

AC2-5

77 x 35 x 77 mm



Two channel universal Controller, ON/OFF or PID

UPDATE

Main Features

- Stylish Capacitive Touch display and keypad technology
- Runs on universal mains power supply
- PID with autotuning or ON/OFF control
- Main output on 12A relay or for SSR-piloting and auxiliary output on 7A relay
- Input for 0÷1V, 0/4÷20mA, PTC/NTC10K, TC J/K or Pt100
- Selectable Refrigerating/Heating (Dehumidifying/Humidifying) control
- Absolute or relative temperature alarms
- Connectivity to supervisory systems and gateway for cloud

Applications

Temperature: Control of heating systems, heated cupboards, bains-marie, ovens, laboratory equipment.

Humidity: Control of greenhouses, seasoning cells, cold rooms, air-conditioned rooms.

How to order AC2-5

Model	Suffix	Opt.	Description
AC2-5			Model and dimensions main unit 5 series
Inputs	A		Input 0...1V
	I		Input 0 / 4...20mA
	J		TC "J" (Iron-Constantan) / TC "K" (Chromel-Alumel)
	P		Thermistor Pt100
	T		PTC1000 / NTC10K
Connections	S		Screw Connections (built in screw terminals)
Outputs	1		Output 1
	2		Output 1 + 2
Type of outputs	R		Outputs on relay
	M		Output 1 on SSR drive, output 2 on relay
Power supply	L*		7 ÷ 30Vdc / 12Vac
	W		100 ÷ 240 Vac
Aux. functions	-		None
	-A		Serial communication TTL
	-B		Serial communication RS485

* In the AC2-5...L version, the power supply of the controller and of the loads must be of type SELV or PELV.

AC2-5 series

TECHNICAL DATA	AC2-5T...		AC2-5P...	AC2-5J...		AC2-5A...	AC2-5I...
Input Type	PTC	NTC10K	Pt100	TC "J"	TC "K"	0÷1V	0/4÷20mA
Range	-50÷150°C -60÷300°F	-40÷125°C -40÷260°F	-100÷850°C -150÷999°F	-50÷750°C -60÷999°F	-50÷999°C -60÷999°F	Configurable in setup	
Accuracy*	±0.3°C ±0.6°F	±0.3°C ±0.6°F	±0.3°C(a); ±1°C(b) < ±2°F	< ±3°C < ±5°F	< ±3mV	< ±0.2mA	
Resolution	0.1 / 1°C / 1°F			1 °C / °F		0.1 / 1	
Max. loads of outputs	OUT1		3.6 FLA; 21.6 LRA 240Vac; 12A resistive				
	OUT2		10A resistive @ 120Vac; 7A resistive @ 240Vac				
	SSR drive for OUT1		15mA 12Vdc				
Power supply	100 ÷ 240 Vac ±10%, 50/60Hz, 3W; 7 ÷ 30Vdc / 12Vac ± 10%, 3W						
Panel-cutout	71 x 29 mm						
Ambient temperature & humidity	-10... +50°C; 15%... 80% rH						

-50÷150°C^(a), ^(b) remaining range.

*approximate (for exact indications, please refer to the instructions for use)

AC2-5

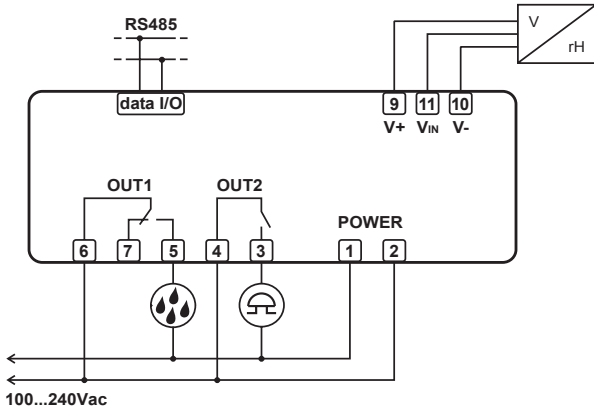

AC2-5AS2RW-B

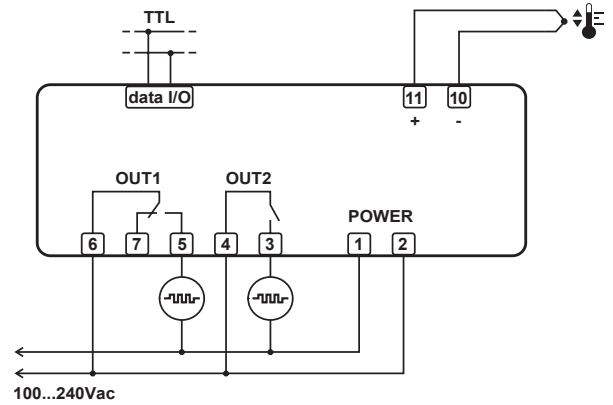

AC2-5JS2RW-A

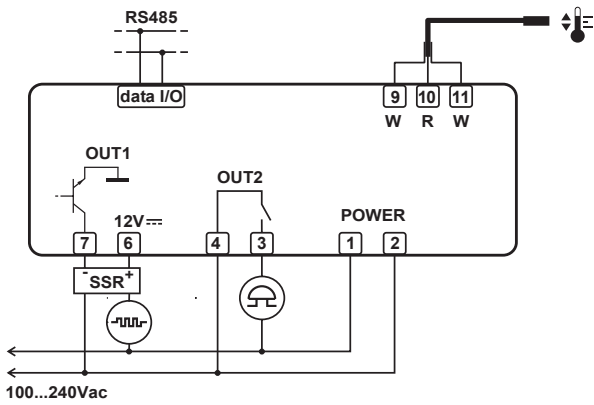

AC2-5PS2MW-B

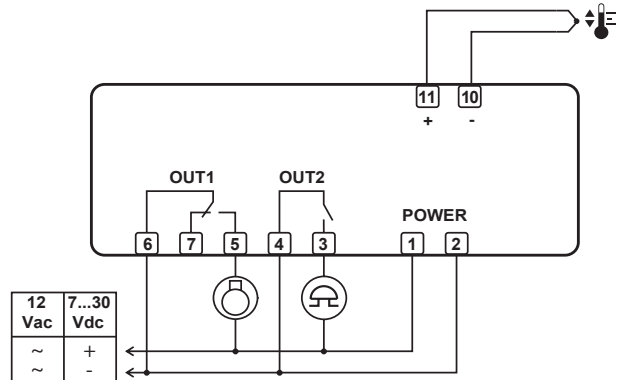

AC2-5JS2RL